

Technical sheet :

MI 45 G



| Technical characteristics | | | Metric |
|---------------------------|--|------------------|--------------------------|
| 1.1 | Manufacturer | | Manitou |
| 1.2 | Model Name | | MI 45 G |
| 1.3 | Power source | | Lpg |
| 1.4 | Operator type | | Seated |
| 1.5 | Max. capacity | Q | 4500 kg |
| 1.6 | Load centre of gravity | c | 500 mm |
| 1.8 | Load distance, centre of drive axle to fork | x | 550 mm |
| 1.9 | Wheelbase | y | 2000 mm |
| Weight | | | |
| 2.1 | Service Weight | | 6500 kg |
| 2.2 | Weight on front axle (laden) / rear axle (laden) | | 9625 kg / 1375 kg |
| 2.3 | Weight on front axle (Unladen) / rear axle (Unladen) | | 2820 kg / 3680 kg |
| Wheels | | | |
| 3.1 | Tyres type | | Super Elastic |
| 3.2 | Dimensions of front wheels | | 300-15-18PR |
| 3.3 | Dimensions of rear wheels | | 7.00-12-12PR |
| 3.5 | Number of front wheels / rear wheels | | 2 / 2 |
| 3.2 | Number of drive wheels | | 2 |
| 3.6 | Front wheel gauge | b10 | 1190 mm |
| 3.7 | Rear wheel | b11 | 1130 mm |
| Dimensions | | | |
| 4.1 | Tilt of Mast Forward (deg) / Backward (deg) | α / β | 6 / 12 |
| 4.7 | Height of overhead guard (cabin) | h6 | 2390 mm |
| 4.7 | Overall height of standard overhead guard | h6 | 2390 mm |
| 4.8 | Seat height/stand height | h7 | 1370 mm |
| 4.12 | Height of towing bar (coupling height) | h10 | 445 mm |
| 4.19 | Overall length | l1 | 4330 mm |
| 4.20 | Length to face of forks | l2 | 3110 mm |
| 4.21 | Overall width | b1 | 1490 mm |
| 4.22 | Forks section / width / length | s / e / l | 50 mm x 150 mm x 1220 mm |
| 4.23 | Fork carriage ISO 2328 (class/form) A/B | | 3A |
| 4.24 | Fork carriage width | b3 | 1250 mm |
| 4.31 | Ground clearance below mast | m1 | 170 mm |
| 4.32 | Ground clearance at centre of wheelbase | m2 | 230 mm |
| 4.35 | Turning radius | Wa | 2800 mm |
| 4.36 | Internal turning radius (over tyres) | b13 | 100 m |
| Performances | | | |
| 5.1 | Travel speed (laden / unladen) | | 13 km/h / 24 km/h |
| 5.2 | Lifting speed (laden / unladen) | | 0.46 Nm / 0.48 Nm |
| 5.3 | Lowering speed (laden / unladen) | | 0.5 Nm / 0.5 Nm |
| 5.5 | Drawbar pull (Laden / Unladen) | | 3800 / 2200 |
| 5.8 | Gradeability - laden (%) / unladen (%) | | 23 / 34 |
| 5.10 | Service brake | | Hydraulic |
| Engine | | | |

| Engine | | | |
|---------------|---|--|------------------------|
| 7.1 | Engine brand / model | | PSI / 4,3L |
| 7.2 | Engine power according to ISO 1585 | | 74 kW |
| 7.3 | Rated speed (rpm) | | 2300 |
| 7.4 | Number of cylinders / Capacity of cylinders | | 6-4300 cm ³ |
| 7.5 | Fuel consumption according to VDI cycle | | 10,6 |
| Miscellaneous | | | |
| 8.2 | Working hydraulic pressure for attachments (bar) | | 160 Bar |
| 8.3 | Oil flow rate for attachments (l/min) | | 90 |
| 8.4 | Measured/guaranteed mean noise level at the ear of the operator | | 83 |

Dimensional drawing

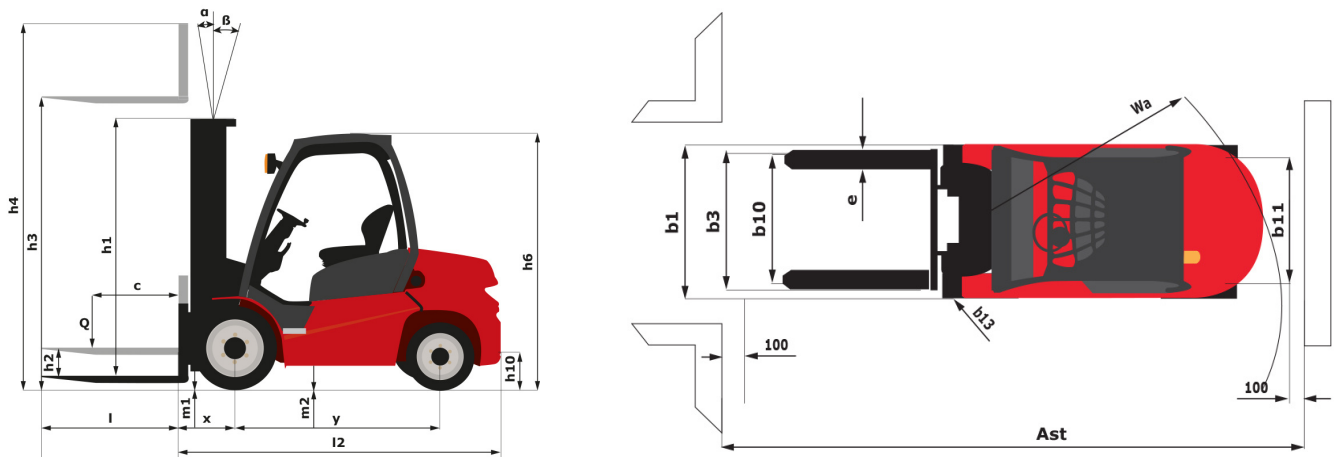

Characteristics of masts and residual capacities

| Full Visibility Duplex | | FVD 30 | FVD 33 | FVD 35 | FVD 37 | FVD 40 | FVD 45 | FVD 50 |
|--|-----|--------|--------|--------|--------|--------|--------|--------|
| h2 - Free lift | mm | 160 | 160 | 160 | 160 | 160 | 160 | 160 |
| h1 - Height mast Lowered | mm | 2245 | 2395 | 2495 | 2595 | 2795 | 3070 | 3345 |
| h3 - Lifting Height | mm | 3000 | 3300 | 3500 | 3700 | 4000 | 4500 | 5000 |
| h4 - Height mast extended | mm | 4170 | 4470 | 4670 | 4870 | 5170 | 5670 | 6170 |
| α / β - Mast inclination (front / rear) | --- | 6 / 12 | 6 / 12 | 6 / 12 | 6 / 12 | 6 / 12 | 6 / 12 | 6 / 12 |
| Residual Capacity without attachment (Industrial load chart) | kg | 1500 | 1500 | 1500 | 1500 | 1500 | 4100 | 3700 |
| Residual Capacity with integrated side shift (Industrial load chart) | kg | 4500 | 4500 | 4500 | 4500 | 4500 | 4000 | 3600 |
| Height at max capacity | mm | 3000 | 3300 | 3500 | 3700 | 4000 | 4000 | 4000 |
| Height at max capacity with integrated sideshift | mm | 3000 | 3300 | 3500 | 3700 | 4000 | 4000 | 4000 |

| Free Lift Duplex | | FLD 30 | FLD 33 | FLD 35 | FLD 37 |
|--|-----|--------|--------|--------|--------|
| h2 - Free lift | mm | 1364 | 1514 | 1614 | 1714 |
| h1 - Height mast Lowered | mm | 2226 | 2376 | 2476 | 2576 |
| h3 - Lifting Height | mm | 3000 | 3300 | 3500 | 3700 |
| h4 - Height mast extended | mm | 4170 | 4470 | 4670 | 4870 |
| α / β - Mast inclination (front / rear) | --- | 6 / 12 | 6 / 12 | 6 / 12 | 6 / 12 |
| Residual Capacity without attachment (Industrial load chart) | kg | 4500 | 4500 | 4500 | 4500 |
| Residual Capacity with integrated side shift (Industrial load chart) | kg | 4500 | 4500 | 4500 | 4500 |
| Height at max capacity | mm | 3000 | 3300 | 3500 | 3700 |
| Height at max capacity with integrated sideshift | mm | 3000 | 3300 | 3500 | 3700 |

| Free Lift Triplex | | FLT 40 | FLT 43 | FLT 45 | FLT 47 | FLT 50 | FLT 55 | FLT 60 |
|--|-----|--------|--------|--------|--------|--------|--------|--------|
| h2 - Free lift | mm | 1229 | 1329 | 1395 | 1459 | 1559 | 1724 | 1939 |
| h1 - Height mast Lowered | mm | 2080 | 2180 | 2248 | 2310 | 2410 | 2575 | 2790 |
| h3 - Lifting Height | mm | 4000 | 4300 | 4500 | 4700 | 5000 | 5500 | 6000 |
| h4 - Height mast extended | mm | 5170 | 5470 | 5685 | 5870 | 6170 | 6670 | 7180 |
| α / β - Mast inclination (front / rear) | --- | 6 / 12 | 6 / 6 | 6 / 6 | 6 / 6 | 6 / 6 | 3 / 6 | 3 / 6 |
| Residual Capacity without attachment (Industrial load chart) | kg | 4450 | 4300 | 4100 | 3900 | 3600 | 3100 | 2500 |
| Residual Capacity with integrated side shift (Industrial load chart) | kg | 4350 | 4200 | 4000 | 3800 | 3500 | 3000 | 2400 |

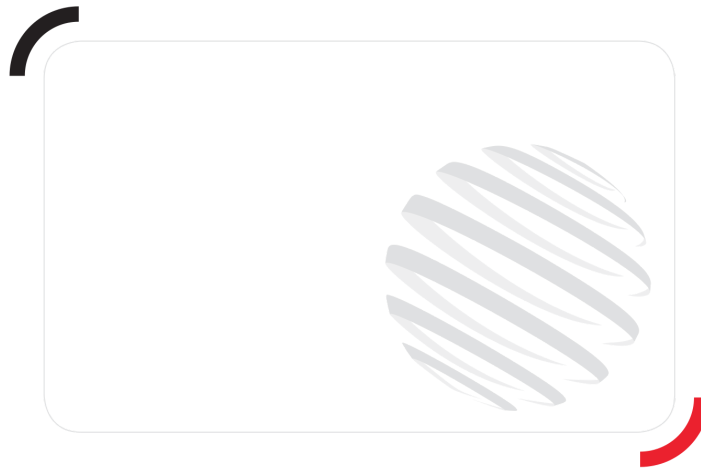

Siège Social
430 rue de l'Aubinière - 44150 Ancenis Cedex - France
Tel: +33(0)2 40 09 10 11 - Fax: +33 (0)2 40 09 10 97
www.manitou.com



This brochure describes versions and configuration options for Manitou products which may be fitted with different equipment. The equipment described in this brochure may be standard, optional or not available depending on version. Manitou reserves the right to change the specifications shown and described at any time and without prior warning. The manufacturer is not liable for the specifications given. For more information, contact your Manitou dealer. Non-contractual document. Product descriptions may differ from actual products. List of specifications is not comprehensive. The logos and visual identity of the company are the property of Manitou and may not be used without authorisation. All rights reserved. The photos and diagrams contained in this brochure are provided for information only.

MANITOU BF SA - Limited company with board of directors - Share capital: 39,547,824 euros - 857 802 508
RCS Nantes